

FoldIR 50-1350mm f/5.5, Motorized Continuous Zoom 680356*

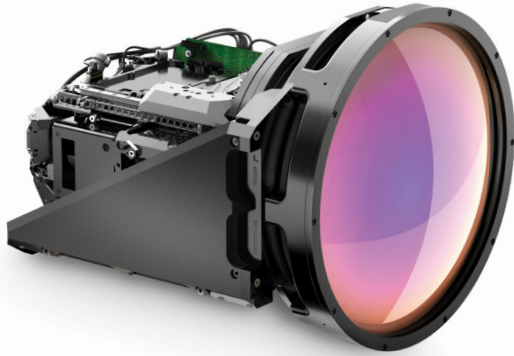

**HD
FORMAT**

WFOV(50mm)

HFOV	640X512	1280X1024
15μ	10.8°	20.5°

NFOV(1350mm)

HFOV	640X512	1280X1024
15μ	0.4°	0.8°

Property

Value

Optical	WFOV	NFOV
Focal Length	50mm	1350mm
F/#	5.5	
Average transmission (3.4-5.0μm)	70% (LRHC)	
Based on Zoom Lens:	28-900mm f/5.5 680072	
Cold stop to FPA Distance	28mm	
Cold Stop CA	Ø5.09mm	
Back Focal Length	37.6mm in air	
Minimum Focus Range	5m	200m
Nuc (by defocus)	Yes	
Mechanical		
Focus Mechanism	Motorized	
Focus Time (minimum range to ∞)	≤8 sec.	
Zoom Mechanism	Motorized	
Zoom Time (NFOV to WFOV)	≤8 sec.	

* Requires export license

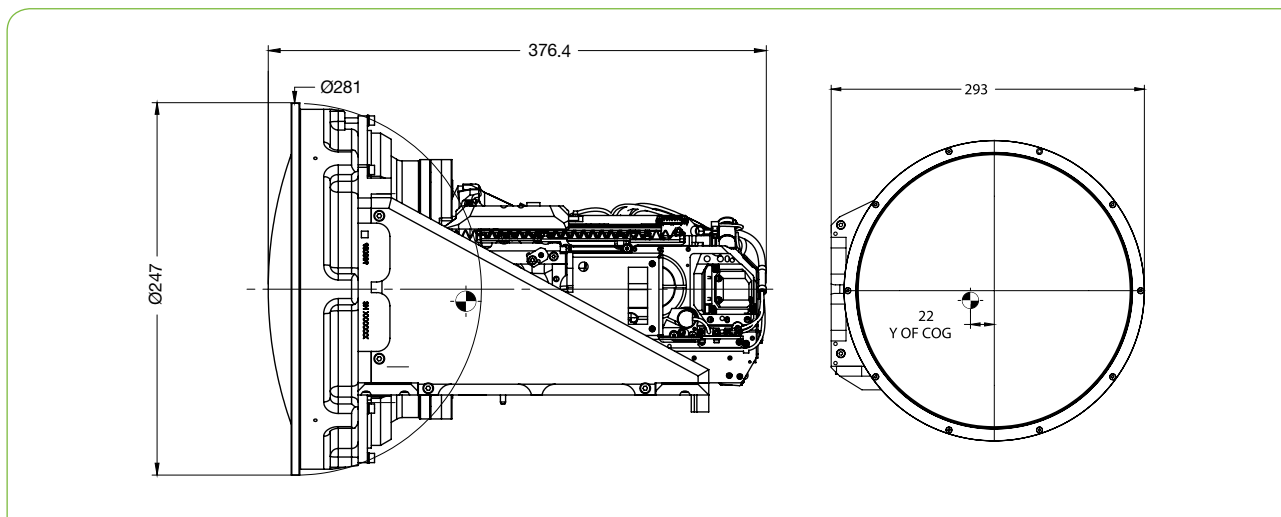

MWIR | ZOOM

Property	Value
Mechanical	
Weight	15.6kg
Max. Dimensions	Length 376.4mm; Ø281mm; height 293mm
Electrical	
Lens Control	Designated lens controller
Supply Voltage	28VDC
Current Consumption	1.25A average, 2.5A peak
Communication Protocol	RS422
Environmental	
Operation Temperature	-20°C to +65°C
Storage Temperature	-54°C to +71°C
Sealing	IP 67 front element only
Configurations	
680356-001	Low Reflection Hard Carbon**

* NOTE: The ICD drawing provided here is primarily a representation and may not accurately reflect the product's actual dimensions and specifications. For precise integration specifications contact your local sales representative.

** For detailed LRHC coating specifications see page 13